

AW CU AW CZ

AND

RANGE

**KITCHEN CUTTERS
AND TWIN MOTOR**



■
Bowl capacity
up to 30 l

■
Commercial
kitchens

■
Gastronomy

■
Butcher shop

■
Canteens

■
Food
processing
industry



Cutter knives stainless steel



Cutting set for mincer made
of stainless steel



Control unit for CU 15

Cutter

- Table unit with 15 litre bowl; floor-mounted unit with 20 and 30 litre bowl
- Ideal for mixing and chopping
- Transparent cutter hood for monitoring and noise protection
- Flow control for even mixing
- One motor with two speeds (CU 15 and 30)
- Two motors with two speeds each (CU 20)
- Secured 3 knife head (CU 15, CU 30); optional: 6 knife head
- Secured 4 knife head (CU 20)
- Restart protection

Twin cutter

- Ideal for blending, chopping and mixing
- Cutter bowls, bearing arms for knife driving shaft, mincer housing, lock ring and funnel made of stainless steel
- Three motors with two speeds each for separate drive for knife driving shaft, bowl and mincer
- Electric knife shaft brake
- Separate drive and motor protection for cutter and mincer
- Restart protection
- Strip cutter as a slip-on device
- Secured 4 knife head

ACCESSORIES AW CZ 20/82

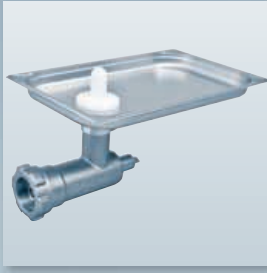

82 mm meat mincer for AW CZ 20/82

For mincing a product volume of up to 250 kg/h.

5-part cutting set made of stainless steel, L&W

Included in the delivery.



Steaker and meat tenderizer for AW CZ
For steaking of raw meat and steaks.

For tenderizing of raw meat slices.

Protection against injury caused by counter-rotating rollers.

TECHNICAL DATA

	AW CZ 20/82	AW CU 15	AW CU 20	AW CU 30
Power supply	400 V, 50 Hz cable with CEE plug	400 V, 50 Hz cable with CEE plug	400 V, 50 Hz cable with CEE plug	400 V, 50 Hz cable with CEE plug
Output (kW) knife driving shaft	2.6 at 1600 min ⁻¹ 3.2 at 3200 min ⁻¹	1.6 at 1420 min ⁻¹ 2.0 at 2840 min ⁻¹	2.6 at 1600 min ⁻¹ 3.2 at 3200 min ⁻¹	3.6 at 1420 min ⁻¹ 4.5 at 2840 min ⁻¹
Output (kW) Cutter bowl	0.12 at 10.3 min ⁻¹ 0.18 at 20.6 min ⁻¹	– –	0.12 at 10.3 min ⁻¹ 0.18 at 20.6 min ⁻¹	– –
Output (kW) Meat mincer	1.4 at 150 min ⁻¹ 1.8 at 300 min ⁻¹	– –	– –	– –
Fuse protection (A)	20	16	16	20
Ingress protection	IP 54 (splash-proofed)	IP 54 (splash-proofed)	IP 54 (splash-proofed)	IP 54 (splash-proofed)
Dimensions (L x W x H)	833 x 972 x 1172 mm	870 x 640 x 550 mm (incl.Bowl) (H max. 920 mm)	785 x 780 x 1096 mm (incl.Bowl) (H max. 1453 mm)	1,030 x 780 x 1130 mm (incl.Bowl) (H max. 1570 mm)
Weight (kg)	222	165	190	330
Bowl capacity (l)	20	15	20	30

AW CZ 20/82
Twin cutter

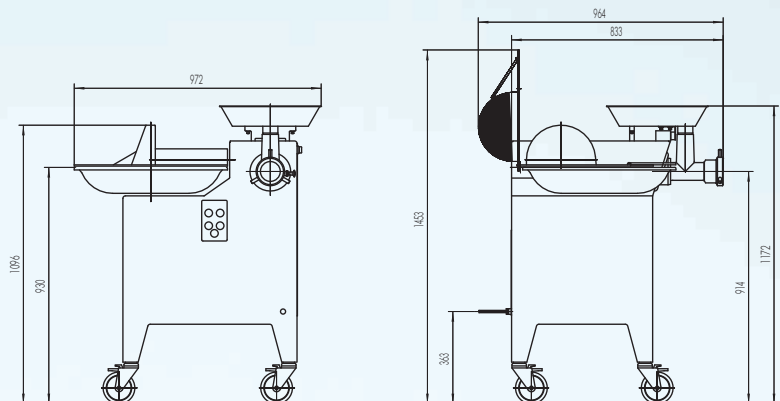

The figures shown here are for illustration only and may deviate from the actual design version. Technical alterations are reserved. For additional accessories please refer to our price list.